

Styled™ Door Face Options

Product Features and Specifications

Interior Only



When you need the rich look of a traditional wood panel door with fire ratings up to 90 minutes, look no further than the Styled Door. These unique flush doors are designed with dimensional applied moulding and rotated veneers for a look of distinct elegance. Internally, however, Styled Doors feature particleboard, staved, structural composite lumber or mineral cores for the fire protection that is required in many applications.

Core Type Available

- DPC-1:** Particleboard Core
- EPC-1:** Environmental Class™ Particleboard Core
- DCL-1:** Structural Composite Lumber Core
- DSC-1:** Staved Core
- ESC-1:** Environmental Class™ Staved Core
- DCL-20:** Fire-Rated Door - Structural Composite Lumber (20-minute) - Neutral & Positive Pressure
- DFP-20:** Fire-Rated Door - Particleboard Core (20-minute) - Neutral & Positive Pressure
- EFP-20:** Environmental Class™ Particleboard Core (20-minute) - Neutral & Positive Pressure
- DFS-20:** Fire-Rated Door - Staved Core (20-minute) - Neutral & Positive Pressure
- ESC-20:** Environmental Class™ Staved Core (20-minute) - Neutral & Positive Pressure
- DFM-45:** Fire-Rated Door - Mineral Core (45-minute) - Neutral & Positive Pressure
- EFM-45:** Environmental Class™ Fire Rated Door - Mineral Core (45-minute) - Neutral & Positive Pressure
- DFM-60:** Fire-Rated Door - Mineral Core (60-minute) - Neutral & Positive Pressure
- EFM-60:** Environmental Class™ Fire Rated Door - Mineral Core (60-minute) - Neutral & Positive Pressure
- DFM-90:** Fire-Rated Door - Mineral Core (90-minute) - Neutral & Positive Pressure
- EFM-90:** Environmental Class™ Fire Rated Door - Mineral Core (90-minute) - Neutral & Positive Pressure

Face Stiles Face Rails Other

The Styled Door is not available as an X-Ray or Sound Retardant
 • 6" or 8" option on doors up to 4/0 wide • 8" or 10" option on doors 4/0 wide
 Top 6", middle 8", bottom 12"
 Mouldings are standard profile 5 and are glued on

- On non-factory machined doors, middle rail will be centered on 40" lock height. For factory machined doors, middle rail will center on actual lock height as specified.
- Due to moulding being applied on both faces, Marshfield DoorSystems recommends the Styled Door be factory-fit, beveled and factory machined.
- Watch for lock/lever and moulding conflicts.
- Color variation will occur between stiles/rails/panels. Horizontal grain of veneer faces will have crossgrain scratches at 180 grit. Scratches may be more apparent when a darker stain is applied.

12 Standard Door Configurations

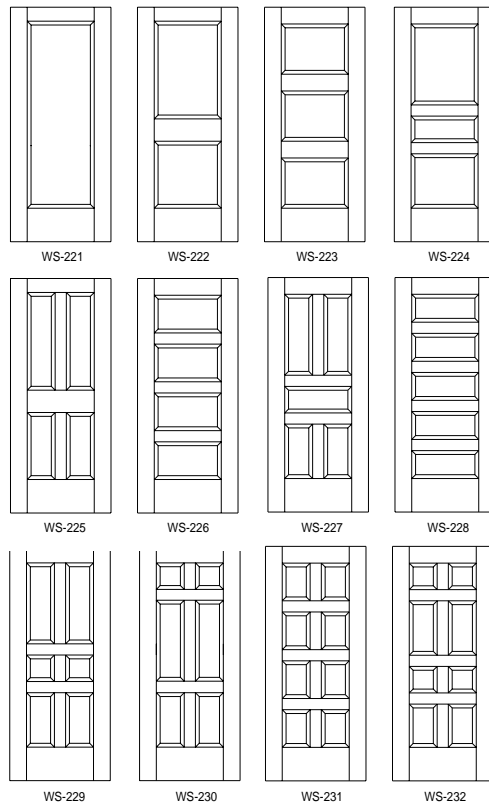

Cross Section of Marshfield DoorSystems Styled™ Door

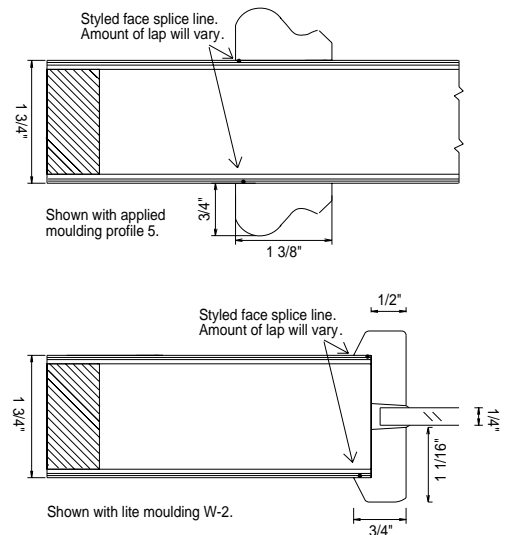

- Moulding is not applied directly to edge of veneer splices.
- Distance from edge of door to splice may vary +/- 3/16".
- Pair match of Styled doors is at meeting edge only.
- Flush lite moulding is not available in Styled doors unless used with an applied moulding border.
- Glass may be installed by Marshfield DoorSystems upon request.

Note: Marshfield DoorSystems, Inc. doors are manufactured per the standards listed on this page. Specifications are subject to change without notice.