

### ABOUT THE PRODUCT:

The L18 and L16-Series Flush Doors are designed to meet the architectural requirements for full flush doors. This premium door construction combines the strength and dimensional stability of steel with the structural integrity of the honeycomb core. The continuous bonding of core to metal provides an attractive flat door, free of face welding marks. Tests have proven that the L-Series door has integral high resistance to impact damage, low thermal conductivity, and high STC ratings.

To meet application, specification and performance requirements, the L-Series doors offer a wide range of specifiable options including sizes, glass lite designs, hardware (mechanical, pneumatic, electrical) preparations and edge constructions.

### FEATURES AND BENEFITS:

Steelcraft's L-Series Doors offer the following standard unique features, which enhance long term performance and durability.

1. **Honeycomb core system** enhances the structural integrity of the door, while significantly reducing the weight.
2. **Full height, epoxy filled mechanical interlock edges** provide structural support and stability the full height of the door edges.
3. **Patented universal hinge preparations** allow for easy field conversion from standard weight (.134) hinges to heavy weight (.180) hinges.
4. **14 gage top and bottom channels** provide stability and protection for the top and bottom edges from abuse.
5. **Beveled hinge and lock edges** allow for tighter installation tolerances, ensure easier operation, and eliminate binding and sticking.
6. **Recessed Designer™ glass trim** provide a clean, neat, and flush finish with the door surface.
7. **Factory applied baked on rust inhibiting primer** in accordance with ANSI A250.10.

### SPECIFICATION COMPLIANCE:

1. Door construction for the Steelcraft L18 and L16-Series Full Flush Doors meet the requirements of ANSI A250.8-1998 (commonly referred to as SDI-100).
2. Hardware preparations and reinforcements are in accordance with ANSI A250.6-1997. Locations are in accordance with ANSI/DHI A115.

### FIRE RATINGS:

The L-Series doors meet the broadest fire rating requirements. They are listed for installations requiring compliance to both negative pressure testing (ASTM E152 and UL-10B) and positive pressure standards (UBC 7-2 and UL-10C)

Steel Thickness	Opening	Usage Frequency <sup>1</sup>	Frame Applications
16 gage (1.3mm)	Interior & Exterior	Extra-heavy duty	<ul style="list-style-type: none"> <li>• 16 &amp; 14 gage steel frames</li> </ul>
18 gage (1mm)	Interior & Exterior	Heavy duty	<ul style="list-style-type: none"> <li>• 16 gage steel frames</li> </ul>
Steel Type	Opening	Building Applications	
Non Galvannealed <sup>3</sup>	Mainly Interior	<ul style="list-style-type: none"> <li>• Typical building conditions</li> </ul>	
Galvannealed <sup>2</sup>	Mainly Exterior	<ul style="list-style-type: none"> <li>• Used in locations with high humidity and/or weather exposure</li> </ul>	

### MATERIAL:

Depending on environmental conditions, exterior doors are generally galvannealed and interior doors non galvanneal. All doors are supplied with a factory applied baked on primer for field applied finish paints.

<sup>1</sup> Usage frequency is based on ANSI A250.8-1998

<sup>2</sup> Reinforcements for galvannealed doors are also galvannealed

<sup>3</sup> Commercial quality carbon steel

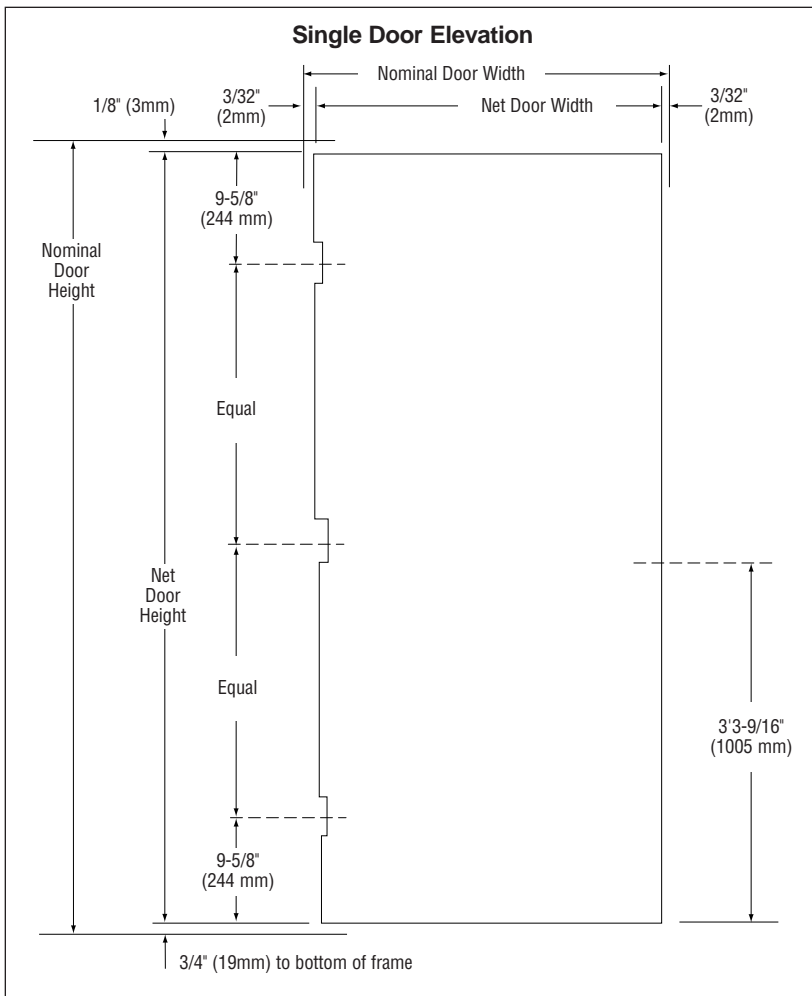

### CONSTRUCTION NOTES:

- Doors** are 1 3/4" (45mm) thick.
- Door opening size maximum:**  
 Single door opening size 4'0" x 10'0" (1219mm x 3048mm)  
 Double door opening size 8'0" x 10'0" (2438mm x 3048mm)
- Standard operating clearances (installed in frame):**  
 Head = 1/8" (3mm) to bottom of head or transom panel  
 Hinge and lock side = 3/32" (2mm) to rabbet on jamb
- Standard core system:**  
 1" (25mm) cell Kraft honeycomb core is laminated to both face sheets with contact adhesive. The honeycomb is phenolic resin impregnated and sanded to insure ultimate lamination and performance. To further enhance the structural stability of the door the honeycomb core material is subjected to several unique operations prior to assembly. If any of these operations are eliminated, the strength and durability of the door is compromised.
- Hardware preparations:** to meet specifications, doors can be prepared for all commercial mortised hardware, and can be factory reinforced for surface applied hardware applications.
  - **Lock preps** – details and dimensions shown are for cylindrical (ANSI 115.2) type locks. For mortise (ANSI A115.1) locks, the centerline of the lock is located 3/8" (9mm) lower.
- Glass lites with Designer® trim and louvers:** doors with glazed cutouts and doors with louvers are available (see *Lites and Louvers* section of *Spec Manual*).

### Beveled Edge with Full Height Mechanical Interlock

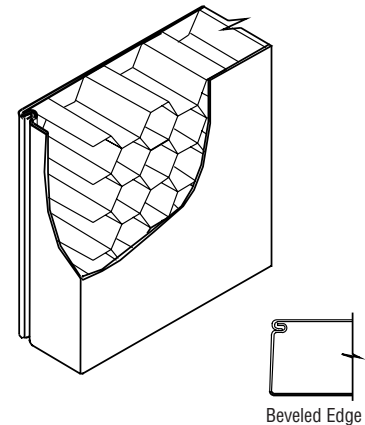

### Inverted Top & Bottom Channels 14 Gage

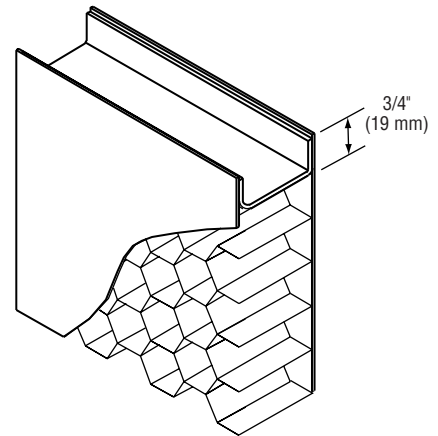

### Designer Trim Option

1/4" – Standard 1/2" – Optional

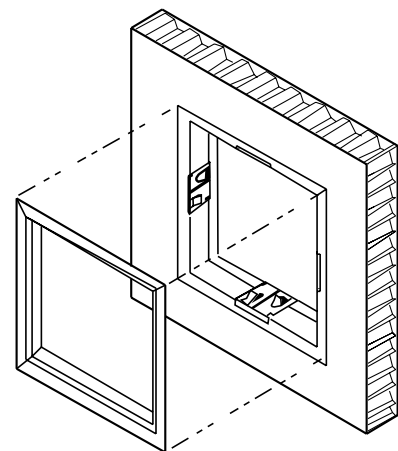

### Universal Mortise Hinge Prep

4½" – Standard 5" – Optional

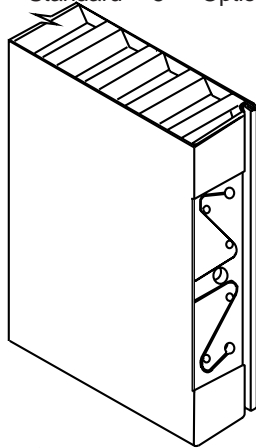

7 Gage Hinge Reinforcement

### Optional Snap-In Top Cap

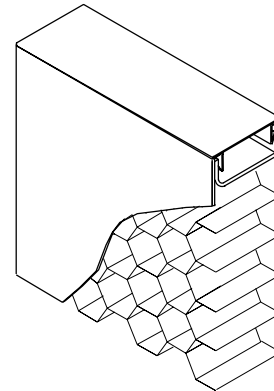

### Lock Prep

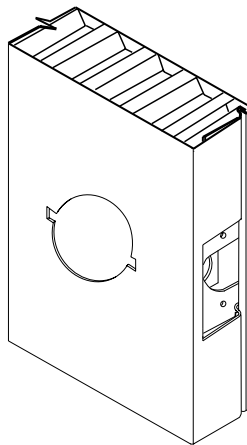

161 Cylindrical Lock shown

### Rigid Honeycomb Core

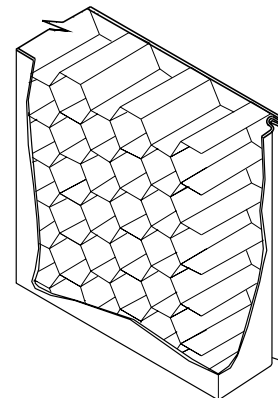

### Optional 14 Gage Closer Reinforcement

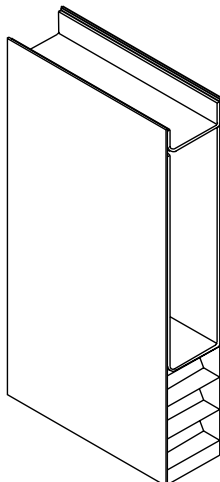

### GENERAL NOTES:

#### 1. Edge construction:

- Vertical edges (both hinge and lock) are beveled with a visible seam.
- Top and bottom edges are closed with inverted 14 gage welded channels. Exterior applications require the addition of snap-in top caps to protect against the weather.

#### 2. Optional edge seams available in the L-Series door construction are as follows:

- **LF** – The mechanical edge seam is filled and finished prior to applying the factory primer.
- **LW** – The mechanical edge seam is welded and finished prior to applying the factory primer.

#### 3. Optional cores available in the L-Series door construction:

- **Polystyrene** for exterior applications in extreme weather conditions.
- **Polyurethane** for exterior applications in arctic weather conditions. Not Fire Rated.

#### 4. Standard hardware preparations: standard mortised and reinforced for:

- **Universal hinge preps** – 4½"(114mm) patented preparation which allows easy and quick field conversion from standard to heavy weight hinges.
- **Locks** – A multitude of standard lock preps are available. The most commonly used with a 4⅞" (124mm) strike are 161, 61L and 86.

## INSTALLATION:

1. Installation shall conform to the published Steelcraft installation instructions, SDI 105 *Recommended Installation Instructions for Steel Frames*, and ANSI/DHI A115-IG *Installation Guide for Doors and Hardware*.
2. Fire Rated Assemblies must be in accordance with NFPA Pamphlet 80. The *Authority Having Jurisdiction* is the final authority in issues related to the installation and use of installed Fire Rated Doors.

## DOOR EDGE APPLICATIONS:

The L-Series Doors are used in virtually all buildings and construction applications. The application and functionality dictate the door edge construction specified.

Edge	Usage	Application
L	Heavy & Extra-heavy duty	High traffic in all commercial applications
LF	Heavy & Extra-heavy duty	High traffic, in sanitation conditions
LW	Heavy & Extra-heavy duty	High traffic, in sanitation and high abuse conditions

## CONVERSION CHART

ANSI A250.8 (SDI 100) *Recommended Specification for Standard Steel Doors and Frames*.

Series	Level	Model	Description	Edge Construction
L18	2	1	Full Flush	Full height, visible mechanical interlocked edge
LF18	2	2	Seamless	L-Series with epoxy filled edge seams
LW18	2	2	Seamless	L-Series with welded edge seams
L16	3	1	Full Flush	Full height, visible mechanical interlocked edge
LF16	3	2	Seamless	L-Series with epoxy filled edge seams
LW16	3	2	Seamless	L-Series with welded edge seams

## DOUBLE DOOR APPLICATIONS:

L-Series doors are available in double door elevations, with active and inactive leaves and an overlapping astragal.

- **Standard operating clearances** (*installed in frame*):
  - Head =  $\frac{1}{8}$ " (3mm) to bottom of head or transom panel
  - Hinge side =  $\frac{3}{32}$ " (2mm) to rabbet on jamb
  - Meeting edges =  $\frac{3}{32}$ " (2mm) with or without astragal. For openings without an astragal, a wide inactive leaf is used.
  - Bottom =  $\frac{3}{4}$ " (19mm) to bottom of frame

### • Meeting edges:

- 14 Gage astragal is furnished loose for installation in the field by others.
- Overlapping astragal kits are available to convert an active leaf to an inactive leaf.
- When an astragal is not used, the width of the inactive leaf is increased  $\frac{3}{32}$ " (2mm).
- **Hardware preparations:** the inactive leaf can be prepared for hardware as specified.

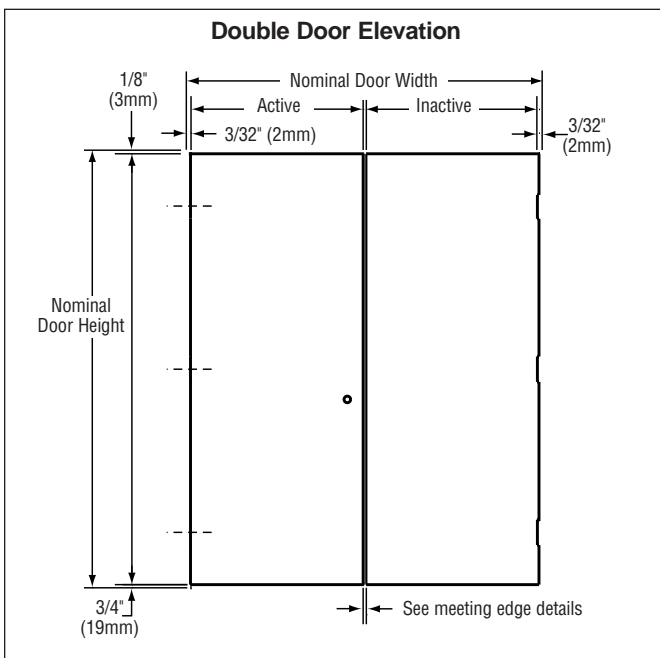

## MEETING EDGE DETAILS:

